

3		4	
MARK	REVISER	DESCRITRN	DATE

K

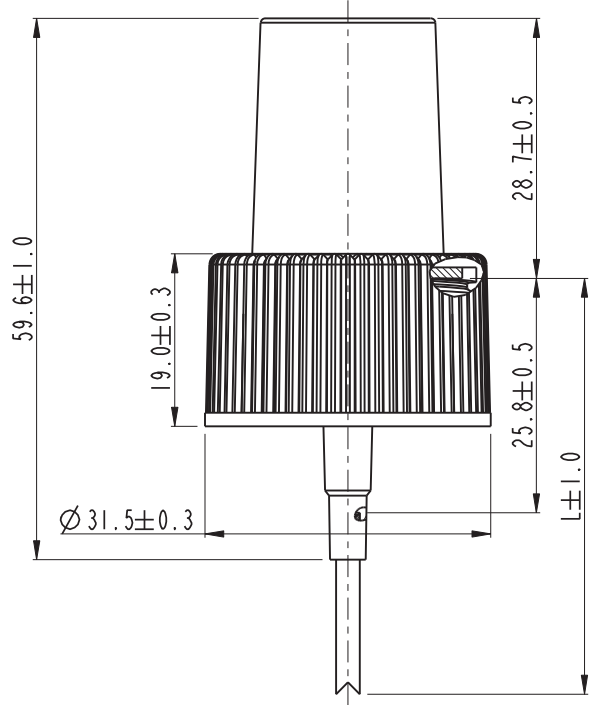
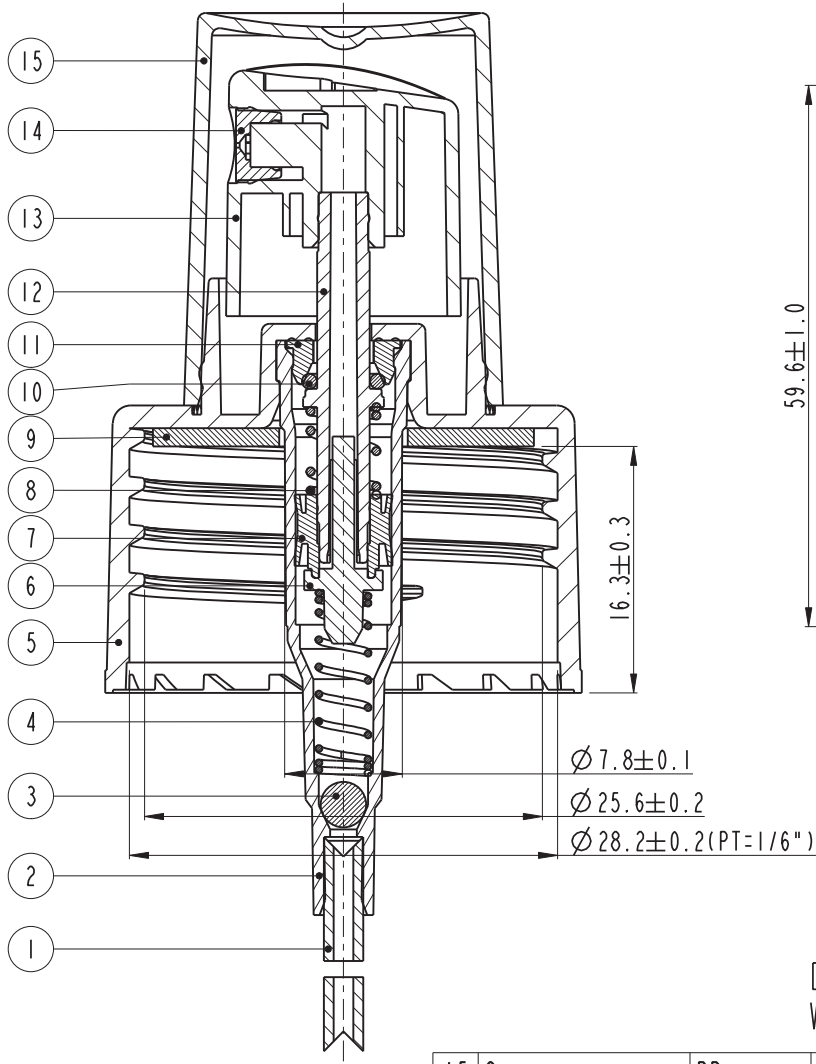

Section A-A
Scale 1.200

Discharge Rate: 0.12 ± 0.02 ml/T
Weight: 7.2 ± 0.5 g (No Dip Tube)

Section A-A

15	Overcap	PP	Color for order form	SSR608-07B1	I	
14	Insert	POM	Color for order form	SSR608-11A1	I	
13	Actuator	PP	Color for order form	SSR608-08A2	I	
12	Stem	POM	Natural	SSR608-04A1	I	
11	Seal	LDPE	Natural	SSR608-22A1	I	
10	Rubber O Ring	NBR	Ø1.0*Ø5.0	SSR608-99A1	I	
9	Gasket	PE	Ø25.2*1.2 thickness	SSR608-98E1	I	
8	Short Spring	SUS304	Ø0.55*9L*5 circle	SSR608-96A1	I	
7	Piston	LDPE	Natural	SSR608-03A1	I	
6	Needle	POM	Natural	SSR608-17A1	I	
5	Ribbed Closure	PP	Color for order form	SSR608-05A9	I	
4	Long Spring	SUS304	Ø0.45*18L*13 circle	SSR608-96B1	I	
3	Ball	Glass	Ø3.0	SSR608-97A1	I	
2	Housing	PP	Color for order form	SSR608-01A1	I	
1	Dip Tube	LDPE	Ø2.6*0.65 thickness	SSR608-95A1	I	
NO.	Component	Material	Specification	Part No.	QTY	Remark

TOLERANCE	Ø		
0mm-15mm	±0.05	±0.10	±0.50
15mm-30mm	±0.05	±0.15	±1.00
30mm-50mm	±0.10	±0.20	±1.50
50mm-99mm	±0.15	±0.30	±2.00
ABOVE 99mm	±0.20	±0.40	±2.50
CENTER	±0.10	±0.50	±1.00
ANGLER	±0.25°	±0.50°	±2.00°

DRAFTER: _____ UNIT: mm

CHECKED: _____ MODEL NAME: _____ TITLE: _____

CENSOR: _____ SCALE: 2:1 VISUAL ANGLE: Q'TY: 1/1 REV: A0

APPROVED: _____ PART NO: _____ FILE NO: _____

D-