

MARK	REVISER	DESCRITRN	DATE

K

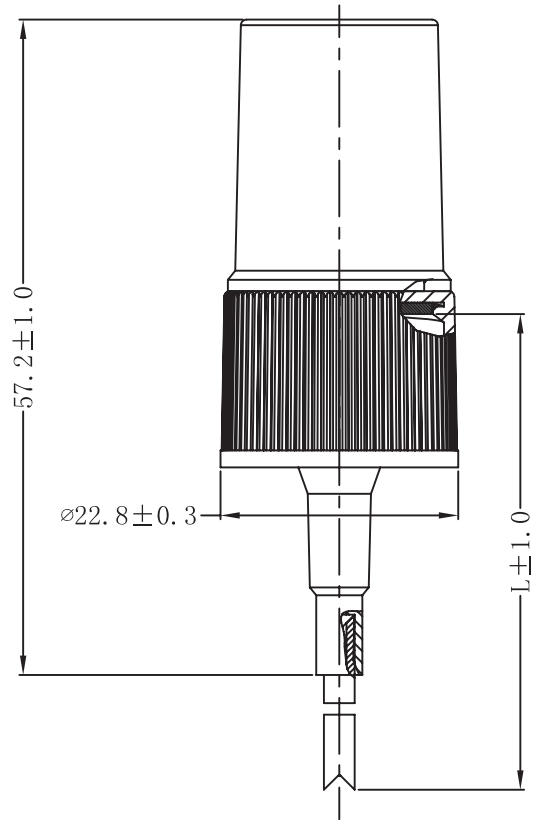
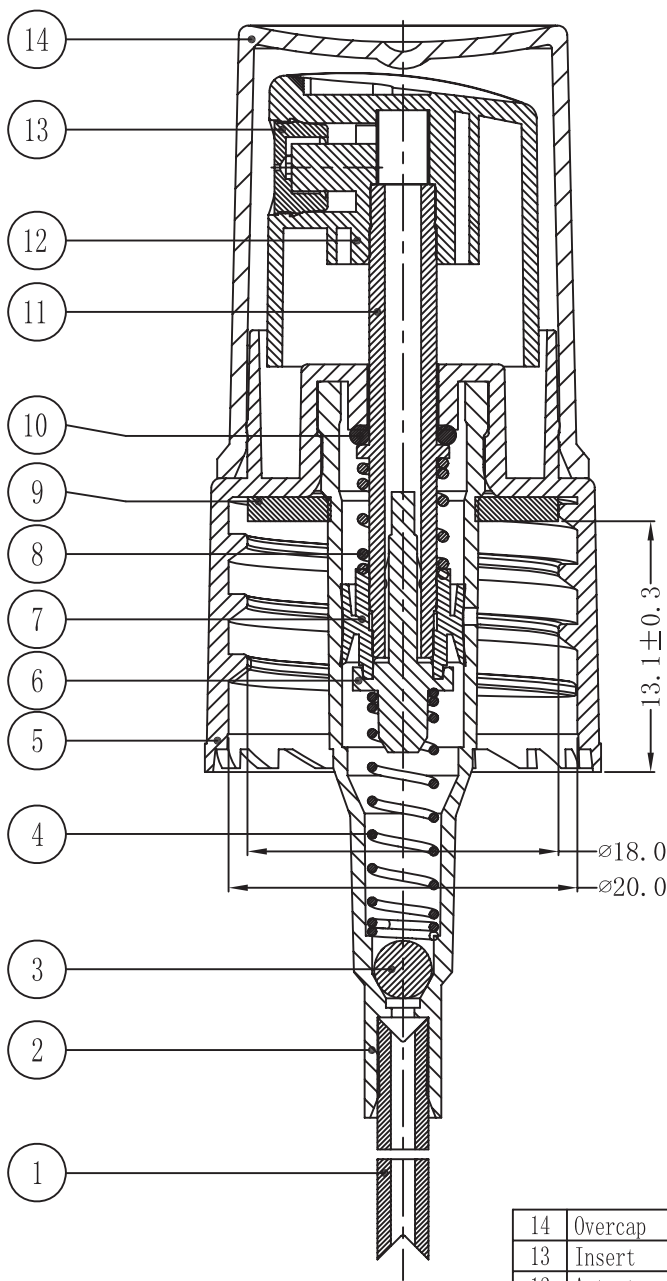

Scale 1.500

Section A-A

14	Overcap	PP	Color for order form	1		
13	Insert	POM	Color for order form	1		
12	Actuator	PP	Color for order form	1		
11	Stem	POM	Natural	1		
10	O Ring	Rubber	∅1.0*∅4.5	1		
9	Gasket	PE	∅17.5*1.2 thickness	1		
8	Short Spring	SUS304	∅0.53*7.2L*5.5 circle	1		
7	Piston	LDPE	Natural	1		
6	Needle	POM	Natural	1		
5	Closure	PP	∅20/410	1		
4	Long Spring	SUS304	∅0.45*17L*13 circle	1		
3	Ball	GLASS	∅3.0	1		
2	Housing	PP	Natural	1		
1	Dip Tube	LDPE	∅2.7*0.7 thickness	1		
NO.	Component	Material	Specification	Part NO.	QTY	Remark

TOLERANCE	○	○	○
0mm-15mm	±0.05	±0.10	±0.50
15mm-30mm	±0.05	±0.15	±1.00
30mm-50mm	±0.10	±0.20	±1.50
50mm-99mm	±0.15	±0.30	±2.00
ABOVE 99mm	±0.20	±0.40	±2.50
CENTER	±0.10	±0.50	±1.00
ANGLER	±0.25°	±0.50°	±2.00°

DRAFTER:	UNIT: mm		
CHECKED:	MODEL NAME:	TITLE: ∅20/410	
CENSOR:	SCALE: 2.5:1	VISUAL ANGLE:	Q' TY: 1/1
APPROVED:	PART NO:	FILE NO:	REV: A0
		D-	

1

2

3

4